

# OLD-MOULDFLOW CONTROL

**HIGHER QUALITY**

**OLD-MouldFlow Control is a thermo-regulation system properly developed in Oldrati S.p.A., in order to improve the products' quality reducing the material scrap.**

OLD-MouldFlow Control is today a standard application for our tools, starting from a simple thermo-regulated layer up to the thermo-regulated injectors with the flow control.

This system allows us to inject directly in the tool cavities, managing the opening and closure phase of each injector, balancing the rubber flow in order to reduce defects, rejects and material scrap.

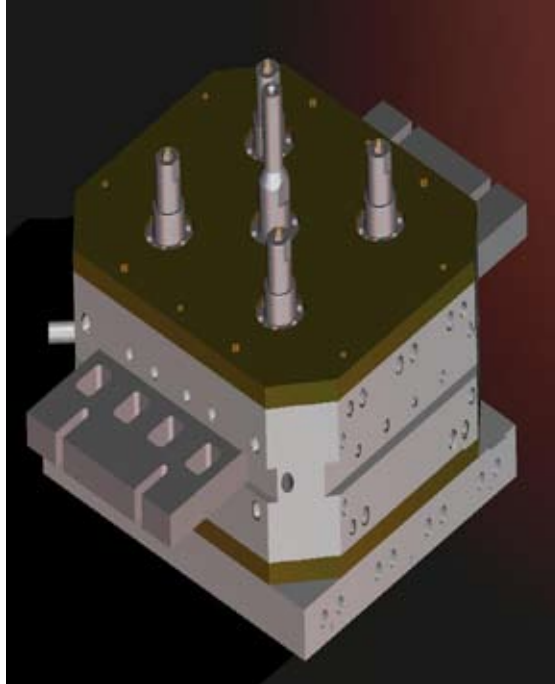

OLD-MouldFlow Control is a system suitable for several applications since it could be fitted in all the tools for rubber, silicon and thermo-plastic materials.

The benefit given using a thermo-regulation system is linked to the material stress reduction in the injection phase and to the better material distribution inside the tool; this means a cycle time reduction, a more uniform vulcanization and a significant reduction of the components' defects.

**OLD-MouldFlow Control means higher quality**

